

T [° C]	R [Ω]
-40	170
0	201
25	219
200	349
400	488
600	616
800	735
850	763

Überwurfmutter
union nut
M14x1,5
SW 17
1.4571

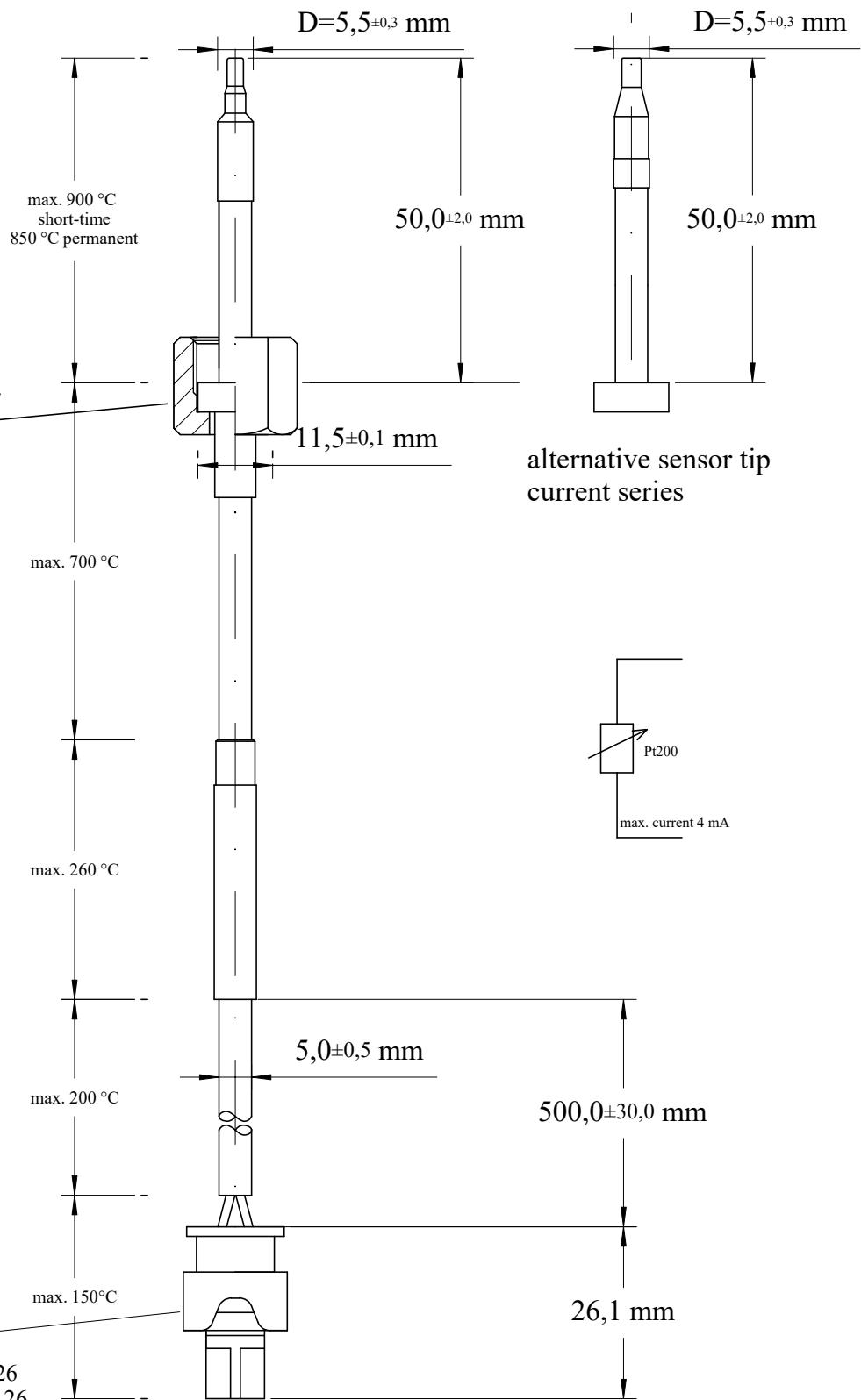

Connector MLK
Housing : Daimler A 025 545 65 26
Terminals: Daimler A 002 982 57 26
Seals: Daimler A 001 545 50 80

insulation resistance
> 20 Mohms @ room temperature
and 500 V DC

Allgemeintoleranzen gem. ISO 2768				Datum	Name	Exhaust gas temperature probe Pt200 HTS-NG Version EngineSens Motorsensor part-no. 20200
			Bearb.	06.02.2025	S. Carstens	
			Gepr.			
			Norm			
				TurboCAD25.0	Maßstab ca. 1:1	
				EngineSens Motorsensor GmbH		Blatt 1/1
				Mannheimer Str. 44b D-68519 Viernheim	phone +49 (0)6204-986 08 23 fax +49 (0)6204-986 08 25	
Index	Änderung	Datum	Name			